

BALDOR® • RELIANCE 

Product Information Packet

IDFRPM25304C

30 HP 1750 TEFC FL2570C (250TC)

Part Detail							
Revision:	-	Status:	PRD/A	Change #:		Proprietary:	No
Type:	AC	Elec. Spec:	L3379A	CD Diagram:	422927-001	Mfg Plant:	
Mech. Spec:		Layout:	617573-023	Poles:	04	Created Date:	04-10-2015
Base:		Eff. Date:	04-13-2015	Leads:			

Specs			
Catalog Number:	IDFRPM25304C		
Enclosure:	TEFC		
Frame:	FL2570C		
Frame Material:	Exposed Laminations		
Output @ Frequency:	30.000 HP @ 60 HZ		
Synchronous Speed @ Frequency:	1800 RPM @ 60 HZ		
Voltage @ Frequency:	460.0 V @ 60 HZ		
Agency Approvals:	CCSA US		
	UR		
Auxillary Box:	No Auxillary Box		
Base Indicator:	Rigid		
Bearing Grease Type:	No Grease		
Current @ Voltage:	39.000 A @ 460.0 V		
Duty Rating:	CONT		
Feedback Device:	NO FEEDBACK		
Frame Prefix:	FL		
Heater Indicator:	No Heater		
Insulation Class:	H		

Mounting Arrangement:	F3		
Product Family:	General Industrial		
Pulley End Bearing Type:	Ball		
Pulley Face Code:	C-Face		
Shaft Ground Indicator:	No Shaft Grounding		
Shaft Rotation:	Reversible		
Motor Standards:	NEMA		
Thermal Device - Bearing:	None		
Thermal Device - Winding:	Normally Closed Thermostat		

Nameplate 000613006NN										
	DUTY	HP	RPM	AMPS	VOLTS	HZ				
	CONT	30	1780	39	460	60				
	CONT	30	3555	36	460	120				
CAT.NO.	IDFRPM25304C		SPEC. NO.	P25T0299						
SER.NO.			FR	FL 2570C	INSUL	H				
PH.	3		MAX SAFE SPEED	5000	AMB.	40			MIN. AMB.	0
DESIGN NO.	L3379A		TYPE		ENCL.	TEFC				
S.F.	1.0		D.E. BRG.	65BC03JPP30A						
ENCL MOD			O.D.E. BRG.	50BC03JPP30A						

Parts List		
Part Number	Description	Quantity
WS286702	WS P25T0299	1.000 EA
RA282910	RA P25T0299	1.000 EA
000613006NN	RPM AC WITH CERTIFIED LOGOS	1.000 EA
000692000FP	NP, WARNING LIFT INSTRUCTIONS	1.000 EA
000692000VD	LABEL WARNING	1.000 EA
036170004EA	ROUND HEAD DRIVE SCREW	4.000 EA
418018122A	LABEL	2.000 EA
422927001	C/D LABEL	1.000 EA
036100080KA	M10-1.50X 80MM HXSOCHDCS	3.000 EA
036500010AB	METRIC NUT M10-1.5PLTD400	4.000 EA
036500010AB	METRIC NUT M10-1.5PLTD400	4.000 EA
036610010AB	MHSLW M10 PLATED	4.000 EA
400638001H	SPRING WASHER (Customer number 43699)	1.000 EA
418057491A	LIFTING LUG	2.000 EA
HA4054	SHORT T-DRAIN FITTING, .125" N.P.T.	1.000 EA
HA4054	SHORT T-DRAIN FITTING, .125" N.P.T.	1.000 EA
609830005ACL	STUD FRAME .375X11.38	4.000 EA
807582003BAA	BRKT,DE,FL250,313 BRG., MACH	1.000 EA
807582004AAB	BRKT,ODE,L250	1.000 EA
032018004AK	HHCS 1/4-20X1/2 PLATED	2.000 EA
034180012FA	KEY 3/8X3/8X1-1/2 L - 360	1.000 EA
036000012HB	HHCS M6X12MM LONG PLATED	3.000 EA
036000045HB	MHHCS M6X45MM PLATED	4.000 EA
036620008AB	M6 METRIC EXT LOCKWASHER	1.000 EA

Parts List (continued)		
Part Number	Description	Quantity
065564000B	GASK 250-280	1.000 EA
075452000B	C/BOX, PAINTED 210-250	1.000 EA
075453000A	CBOXC, PAINTED 250-280	1.000 EA
078548001T	FAN 250	1.000 EA
406673002AE	2" CAP PLUG	1.000 EA
406673002C	.75 CAP PLUG	1.000 EA
415000103A	T/LUG #14AWG-#4AWG W/HOLE FOR .250 BOLT	1.000 EA
415072001B	CLAMP	1.000 EA
417733004AC	GASK C/BOX	2.000 EA
418018074A	GROUND LABEL G100 METRIC 160 D.C.	1.000 EA
418057373A	SCREW SHEET METAL	7.000 EA
708533003A	PLATE, BTM FAN/BLOWER	2.000 EA
708534050A	BLOWER SHROUD	1.000 EA
708534051A	FL250 FAN GRILL	1.000 EA
000640000P	TAG WINDING THERMOST	1.000 EA
004824007K	SPECIAL PAINT	0.100 EA
034180022FA	KEY 3/8X3/8X2-3/4 L	1.000 EA
418010012J	CONDUIT BOX SPACER	1.000 EA

REL. S.O.	-	VOLTS	460	ENCLOSURE	TEFC	WYE CONN EQ CKT OHMS PER PHASE
FRAME	FL2570	AMPS	39	MAX SAFE RPM	5000	(AT BASE RATING, 25 °C)
HP	30	DUTY	CONT	IM (AMPS)	20	R1 .106 X1 .513
BASE SPEED	1780	S.F.	1.0	P.F.@NL/FL	.054/.796	R2 .0656 X2 .782
PHASE/HERTZ	3/60	AMB °C/INSUL	40/H	WK ² (LB-FT ²)	3.5	XM 1.3.4

RATED FULL LOAD DATA

	RPM	HP	TORQUE LB-FT	FUND VOLTS	FREQ-HZ	AMPS
BASE SPEED	1780	30.0	89	460	60	38.7
MAX SPEED	3555	30.0	44	460	120	35.7
MIN SPEED	0	0	89	11.7	.682	38.7

LOAD PERFORMANCE AT BASE SPEED

	RPM	HP	TORQUE LB-FT	FUND VOLTS	FREQ-HZ	AMPS
NO LOAD	1800	0	0	460	60	19.3
1/4	1795	7.51	22	460	60	21.5
1/2	1790	15.0	44	460	60	25.8
3/4	1785	22.5	66	460	60	31.8
FULL LOAD	1780	30.0	89	460	60	38.7
O/L	1756	59.2	177	460	60	70.3

BLOWER DATA

VOLTS	PH/HZ	FL AMPS	LR AMPS	FRAME	CFM

REMARKS: TYPICAL DATA
CORRELATED DATA

	DR. BY	B. GRANT	A-C MOTOR PERFORMANCE DATA L3379A ISSUE DATE 2-12-07
	CK. BY	T. CUER	
	APP. BY	8-11-06	
	DATE		

REL. S.O.	-	VOLTS	460	ENCLOSURE	TEFC	WYE CONN EQ CKT OHMS PER PHASE
FRAME	FL2570	AMPS	39	MAX SAFE RPM	5000	(AT BASE RATING, 25 °C)
HP	30	DUTY	CONT	IM (AMPS)	20	R1 .106
BASE SPEED	1780	S.F.	1.0	P.F.@NL/FL	.054/.796	R2 .0656
PHASE/HERTZ	3/60	AMB C/INSUL	40/H	WK ² (LB-FT ²)	3.5	X1 .513
						R2 .0656
						X2 .782
						XN 13.4

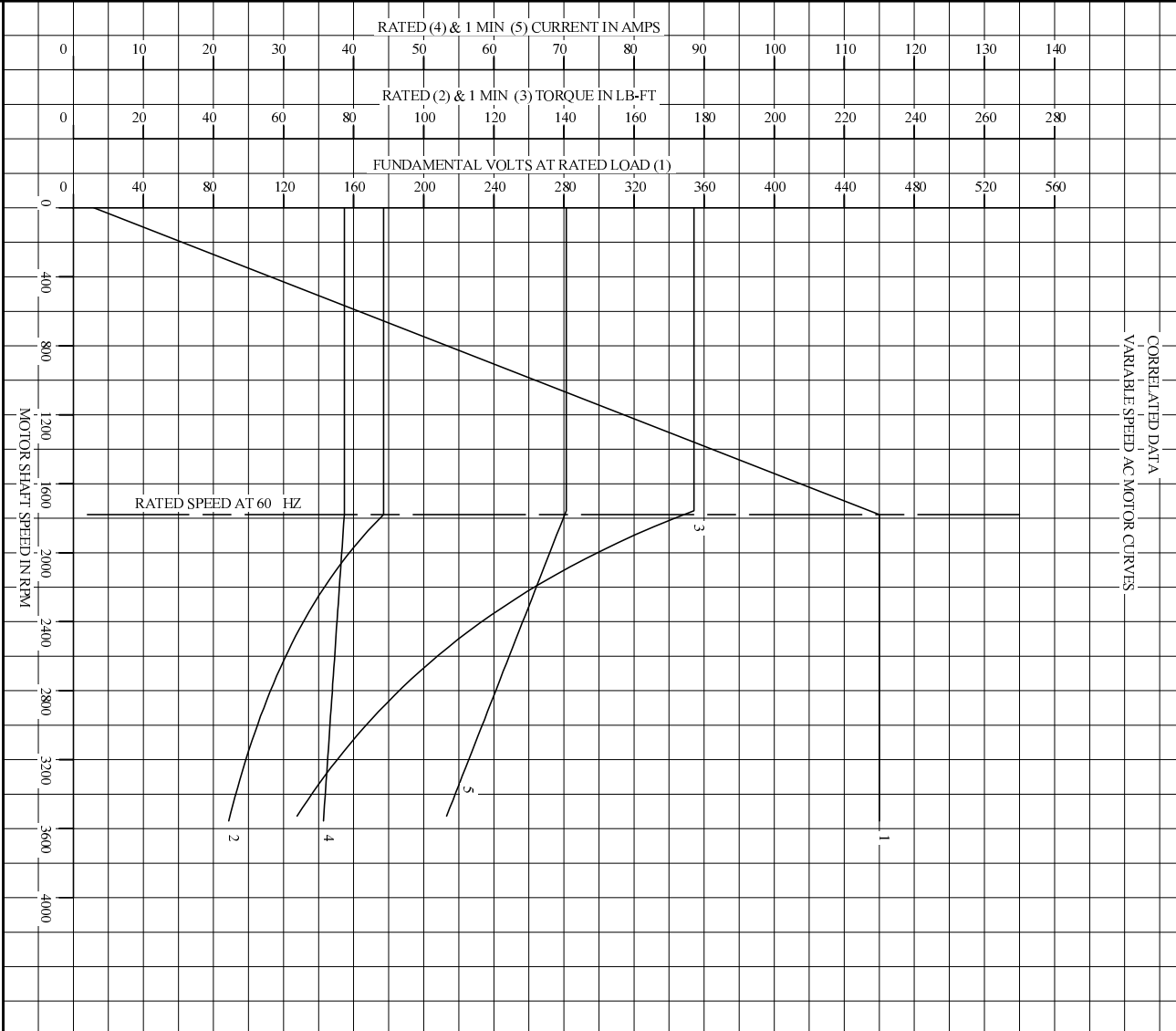

REMARKS: TYPICAL DATA
DATA VALID FOR NAMEPLATE SPEED RANGE ONLY

	DR. BY	B. GRANT	A-C MOTOR PERFORMANCE CURVES	L3379A SH 1 OF 2 ISSUE DATE 2-12-07
	CK. BY	B. GRANT		
	APP. BY	T. CURR		
	DATE	8-11-06		

REL. S.O.	-	VOLTS	460	ENCLOSURE	TEFC	WYE CONN EQ CKT OHMS PER PHASE
FRAME	FL2570	AMPS	39	MAX SAFE RPM	5000	(AT BASE RATING, 25°C)
HP	30	DUTY	CONT	IM (AMPS)	20	R1 .106 X1 .513
BASE SPEED	1780	S.F.	1.0	P.F.@NL/FL	.054/.796	R2 .0656 X2 .782
PHASE/HERTZ	3/60	AMB C/INSUL	40/H	WK ² (LB-FT ²)	3.5	XN 13.4

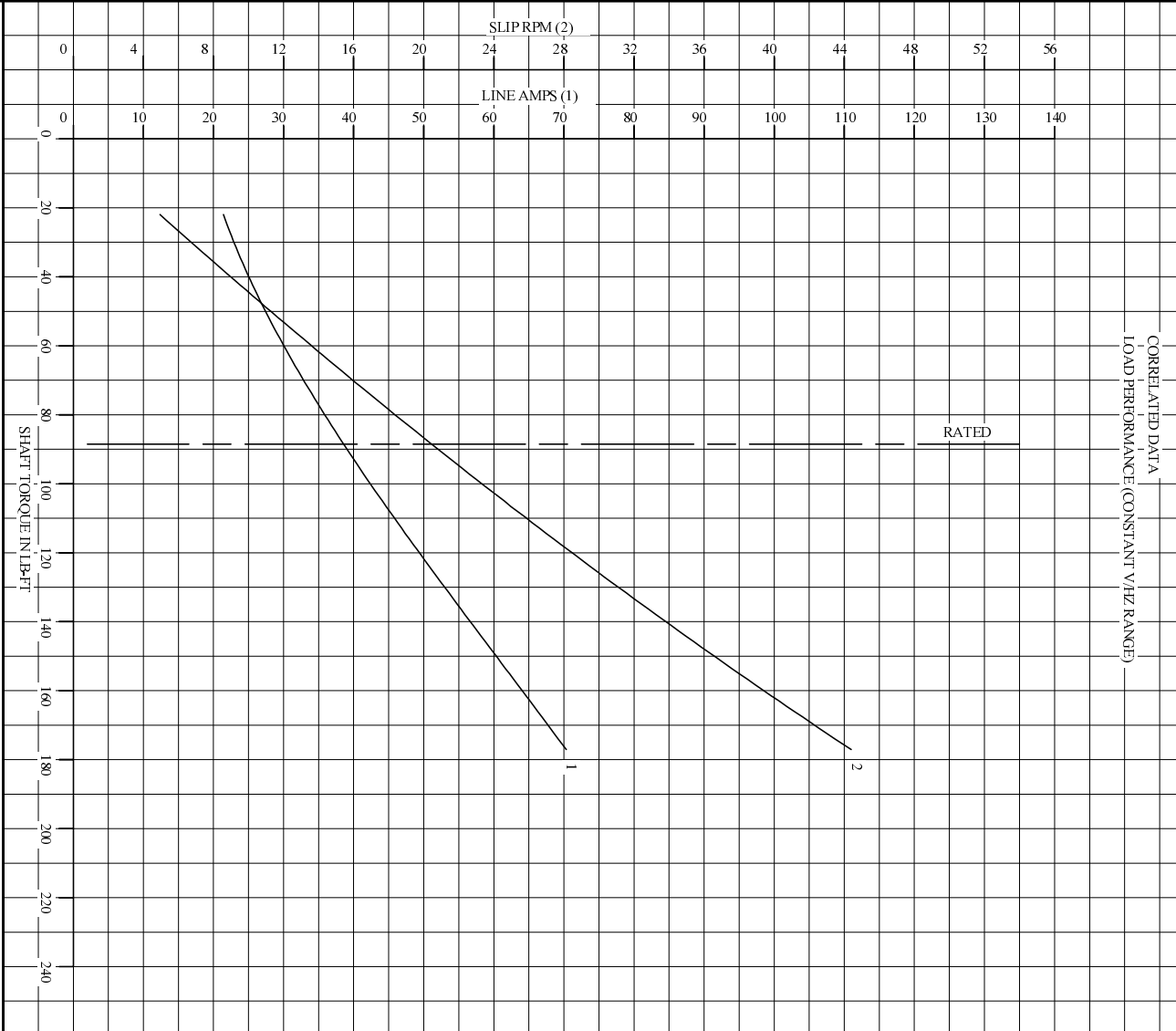

REMARKS: TYPICAL DATA
DATA VALID FOR NAMEPLATE SPEED RANGE ONLY



DR. BY B. GRANT
CK. BY B. GRANT
APP. BY T. CURR
DATE 8-11-06

**A-C MOTOR
PERFORMANCE
CURVES**

L3379A
SH20F2
ISSUE DATE 2-12-07

617573-023

RPM-AC FINNED FRAME VARIABLE SPEED ALTERNATING CURRENT MOTOR
FL2570C

ENCLOSURE: TOTALLY ENCLOSED
MOUNTING: FOOT / NEMA 250TC C-FACE
DRIVE METHOD: COUPLED OR BELTED

COOLING: BLOWER COOLED or
FAN COOLED

ACCESSORIES: PROVISIONS FOR
TACHOMETER MOUNTING
ONLY WHEN SPECIFIED

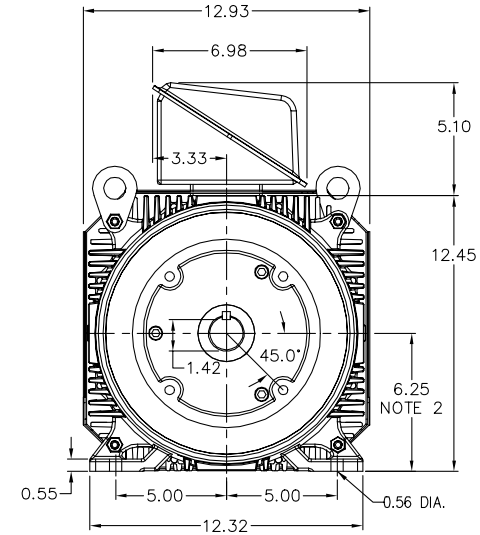
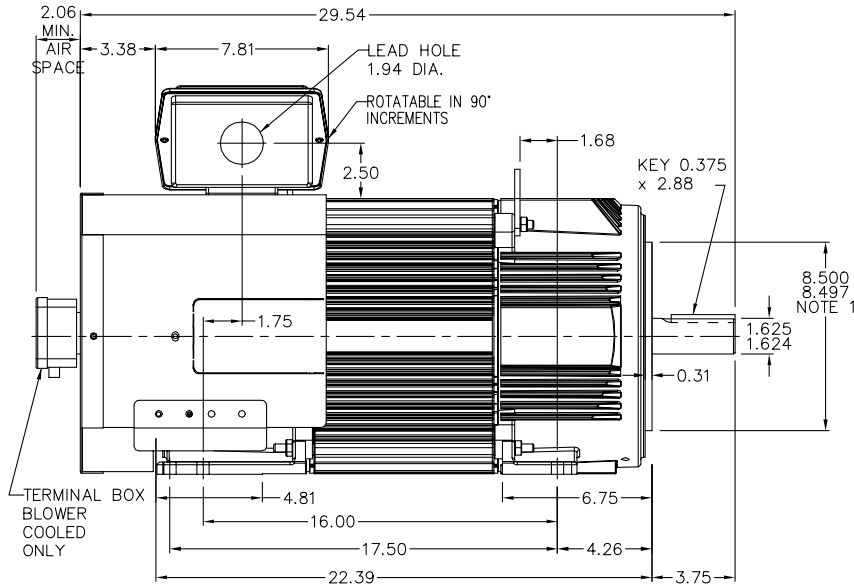

NOTE 1: C-FACE & TACHOMETER MOUNTING
1/2-13 TAP, 1.00 DEEP, ON A 7.25 DIA. BOLT CIRCLE
FACE RUNOUT AND ECCENTRICITY 0.004 MAX. T.I.R.

NOTE 2: SHAFT HEIGHT WILL NOT BE EXCEEDED
SHIMS UP TO 0.03 INCHES IN THICKNESS ARE USUALLY
REQUIRED FOR COUPLED OR GREARED MACHINES

TERMINAL BOX MAY BE LOCATED F1 OR F2 IF SPECIFIED
121 AMP STEEL TERMINAL BOX SHOWN
REFER TO 616779-50 FOR SPECIFIED TERMINAL BOX DIMENSIONS
REFER TO 616779-55 FOR SPECIFIED TACHOMETER DIMENSIONS

MOTOR WEIGHT: 475 LBS. (MAY VARY 15%)
DIMENSIONS ARE IN INCHES SCALE: 1.00

CUSTOMER IS RESPONSIBLE FOR DETERMINING THAT BALDOR'S PRODUCT WILL PERFORM SUITABLY IN THE INTENDED APPLICATION.

REV. DESC: ADDED C-FACE DEPTH DIMENSION

REV. LTR: A VERSION: 01

TDR: 000000493632

FILE: \RGG\00003\142

REVISED: 14:34:48 03/13/2009

BY: CONDLM

MTL: -

BALDOR • DODGE • RELIANCE

DIM SHT FL2570C RPM AC TE FT/NEMA 250TC MTG BLWR OR FAN COOL

SH 1 of 1

617573-023

616779-050

INDUSTRIAL ALTERNATING CURRENT MOTORS

RPM AC

STEEL, CAST IRON, MILL AND TERMINAL BOARD CONDUIT BOX DIMENSIONS
 NEMA FRAMES FL210 thru FL280 and IEC FRAMES RDL132 thru RDL180
 NEMA FRAMES FL180 thru FL280 and IEC FRAMES FDL112 thru FDL180

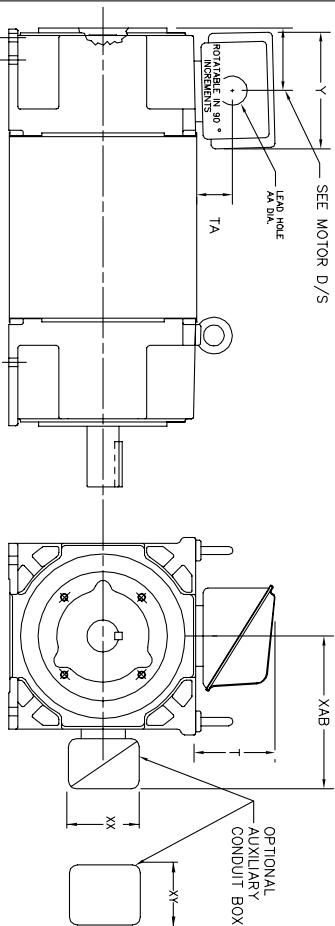

FRAME	TYPE	TERMINAL STRIP	AMPS	C/BOX	Y	TA	T	AA
FL180	STEEL	N	40	706320003A	5.00	1.62	3.00	1.12
FL180	STEEL	Y/N	7/5	706320005A	6.12	2.38	4.38	1.75/2.00
FL180	STEEL	N	208	706320007A	7.62	2.00	7.00	2.50/3.00
FL180 & FDL11	CAST IRON	Y/N	60	706320004C	5.75	2.38	4.38	1.0 TAP
FL180 & FDL11	MILL	Y	100	706310056A	7.75	2.30	4.40	PG29/PG16

FL210 & RL210	STEEL	N	61	0754520008	6.34	2.00	4.12	1.75
FL210 & RL210	STEEL	N	121	075454001AJ	7.69	2.38	5.25	1.94
FL210 & RL210	STEEL	N	305	706320016A	9.00	4.12	8.44	4.59
FL210 & RL210	CAST IRON	N	110	0754600628	7.25	2.50	5.25	1.5 TAP
FL210 & RL210	MILL	Y	100	706310225R	7.75	2.30	4.40	PG29/PG16
FL210 & RL210	MILL	Y	160	706310226R	9.00	3.06	5.40	PG36/PG16
FL210 & RL210	MILL	Y	160	706310056B	9.00	3.06	5.40	PG36/PG16
FDL13 & RDL13	MILL	Y	400	706310063B	14.39	7.43	12.15	BLANK

FL250 & RL250	STEEL	N	61	0754520008	6.34	2.00	4.12	1.75
FL250 & RL250	STEEL	N	121	075454001AJ	7.69	2.38	5.25	1.94
FL250 & RL250	STEEL	N	305	706320016A	9.00	4.12	8.44	4.59
FL250 & RL250	CAST IRON	N	110	0754600628	7.25	2.50	5.25	1.5 TAP
FL250 & RL250	CAST IRON	N	210	706320013A	10.50	4.88	9.00	4.0 TAP
FL250 & RL250	CAST IRON	N	510	706320014D	15.00	7.56	12.81	5.0 TAP
FL16 & RDL16	MILL	Y	100	706310056A	7.75	2.30	4.40	PG29/PG16
FL250 & RL250	MILL	Y	160	706310226R	9.00	3.06	5.40	PG36/PG16
FL16 & RDL16	MILL	Y	160	706310056B	9.00	3.06	5.40	PG36/PG16
FL250 & RL250	MILL	Y	400	706310063B	14.39	7.43	12.15	BLANK

FL280 & RL280	STEEL	N	160	706320009A	7.25	3.50	7.06	2.50
FL280 & RL280	STEEL	N	305	706320016A	9.00	4.12	8.44	4.59
FL280 & RL280	STEEL	N	500	702658001C	14.62	7.56	12.70	5.00
FL280 & RL280	CAST IRON	N	140	706320012B	9.25	4.81	8.58	3.0 TAP
FL280 & RL280	CAST IRON	N	210	706320013A	10.50	4.88	9.00	4.0 TAP
FL280 & RL280	CAST IRON	N	510	706320014D	15.00	7.56	12.81	5.0 TAP
FL16 & RDL16	MILL	Y	100	706310056A	7.75	2.30	4.40	PG29/PG16
FL16 & RDL16	MILL	Y	160	706310056B	9.00	3.06	5.40	PG36/PG16
FL280 & RL280	MILL	Y	160	706310056B	9.00	3.06	5.40	PG36/PG16
FL280 & RL280	MILL	Y	400	706310063B	14.39	7.43	12.15	BLANK

FRAME SIZE	OPTIONAL AUXILIARY CONDUIT BOX DIMENSIONS (MAXIMUM)								
	XAB	XX	XY	PART NUMBER	FRAME SIZE	XAB	XX	XY	PART NUMBER
FL210/TL180/RL210/VL132	7.38	4.25	4.25	603C007-26-A	FL210/TL180/RL210/VL132	10.88	8.00	8.00	706310-3-B
FL250/TL180/RL250/VL160	8.44	4.25	4.25	603C007-26-A	FL250/TL180/RL250/VL160	11.88	8.00	8.00	706310-3-B
FL280/TL180/RL280/VL180	9.12	4.25	4.25	603C007-26-A	FL280/TL180/RL280/VL180	12.62	8.00	8.00	706310-3-B

- (1) TAP CONDUIT
 - (2) TAP PIPE TAP
 - (3) CUSTOMER TO PROVIDE HOLE FOR CONDUIT.
 - (4) 2" DN -5A or 1" TAP DN -4C
- TERMINAL BOX CAN BE KEPT FOR LEAD OUTLET AT TOP. SIZES DR BOTTOM TERMINAL BOX CAN BE KEPT FOR LEAD OUTLET AT BOTTOM. SIZES DR TOP. DR C-1 MOUNTING IS SPECIFIED. DRX LOCATED ON TOP WHEN SPECIFIED.

050-667919

CUSTOMER IS RESPONSIBLE FOR DETERMINING THAT BALDOR'S PRODUCT WILL PERFORM SUITABLY IN THE INTENDED APPLICATION.

REV. DESC: ADD C/BOX 706310-225 & -226R	VERSION: 05	TDR: 000001093792
REV. LTR: E	REVISED: 07: 27: 52 12/18/2018	BY: RGGWT
FILE: \RGG\00003\692		
MTL: -		

BALDOR - RELIANCE®

DIM SHT NEMA RL210-RL280 FL180-FL280 IEC RDL132-RDL180

SH 1 of 1

422927-001

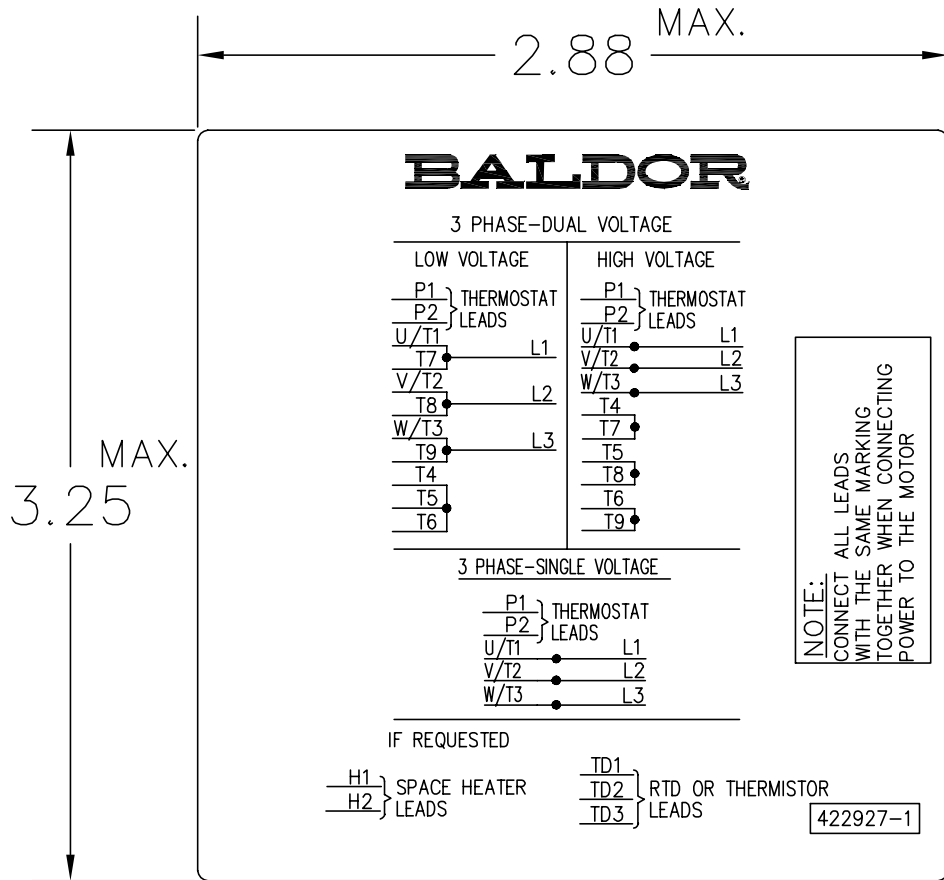

NOTE:
DATA TO BE SIZED
SO THAT IT FITS INTO
MATERIAL DECAL
DIMENSIONS. MAKE
LETTERS & NUMBERS
AS LARGE AS POSSIBLE.

MATERIAL: CERAMATIC DGF-P4
PERMA GRIP ADHESIVE

ALL LETTERS, NUMBERS
AND LINES TO BE BLACK
ON WHITE BACKGROUND.

REV. DESC: CHANGE BACKGROUND COLOR FROM GOLD TO WHITE		
REV. LTR: B	VERSION: 02	TDR: 000000788708
FILE: \RGG\00000\203	REVISED: 08:09:29 03/04/2013	
MTL: -	BY: RGGWT	

BALDOR

EXTERNAL CONNECTION LABEL

SH 1 of 1

422927-001

Marketing maintained PDF of MN406:

<http://www.baldor.com/support/Literature/Load.ashx/MN406?ManNumber=MN406>